

# **2008 Formula First Rules**

(Effective 1/1/08)

These rules use a slightly different numbering system from the SCCA GCR. Rules are grouped by subject matter. Principal points in each subject use two numbers separated by a period ("1.1"). For each subsidiary point a period and another number is added ("1.1.1"). This makes it easy to cite individual points.

These rules describe and specify Formula First racing cars. Formula First is an open wheel class using predominantly Volkswagen production components in a single seat body with a steel frame. It is an evolution of Formula Vee, using a wider range of components. **FORMULA FIRST DOES NOT DISPLACE FORMULA VEE.** A Formula First car is ineligible for Formula Vee. The intent of these rules is to provide for cars of substantially equal performance with moderate construction cost, low operating cost, and high reliability and longevity.

## **1. Definition**

**1.1.** Formula First is a class for single seat racing cars based on components from the standard Volkswagen Types 1 sedan, as originally manufactured by Volkswagen from 1966 to 2004. Since it is a restricted class, all allowable modifications are stated herein. The purpose of the Formula First class is to emphasize driver ability and to encourage the participation of owner/builders and owner/preparers while using proven Volkswagen components (or exact replicas). Homologation is required for all cars registered after January 1, 1983. Homologation for FS classification is required on all Formula First cars.

**1.2.** No component of the engine, power train, front suspension, or brakes shall be altered, modified, or changed, nor be of other than VW manufacture (or an exact replica thereof), unless specifically authorized herein. Mass-produced, direct replacement components may be substituted for original VW components. These replacement components must be constructed of similar to original material(s), maintain the original function(s) and general dimension(s) of the original VW components they replace. If the Official Formula First rules committee deems necessary for a part to be substituted that does not meet the above criteria, then that part and only that one can be labeled as a direct replacement in the rules package. Furthermore, these replacement parts must be generally available to all competitors and offer no competitive advantage over the original VW parts. There are no exceptions. **IF IN DOUBT, DON'T.**

**1.3.** Any VW Type 1 component, of VW manufacture or an exact replica in size, shape, and material, may be used unless a specific part (VW or aftermarket) is specified.

**1.4.** All measurements given in these rules are exact unless a specific tolerance is stated. A car exceeding any measurement or outside a tolerance, **BY ANY AMOUNT** is not in compliance.

**1.5.** Any external surface of the suspension, brakes, and transmission/rear axle tubes may be painted, plated, or anodized.

**1.6.** Weights and Measurements.

**1.6.1.** Minimum weight, as qualified or raced, with driver: 1125 pounds

**1.6.2.** Wheelbase minimum 81.5"; maximum 85.5"

**1.6.3.** Front track maximum: 57" at zero camber & toe

1.6.4. Rear track maximum: 55" at zero camber & toe

1.6.5. Overall length: Maximum 140" (includes exhaust)

## 2. Suspension

### 2.1. Front Suspension.

The front suspension shall be standard VW Type 1 sedan ball joint H-beam front suspension or an exact replica of one of them and dimensionally identical. The following modifications are permitted:

2.1.1. Lugs may be welded, brackets attached by welding or otherwise, and holes drilled in the ball joint H-beam to permit attachment of the beam to the chassis, and other components wholly or partially to the beam. Brackets may be welded to the torsion arms for the sole purpose of actuating the shock(s) and/or external mounted anti-roll bar and shall perform no other function.

2.1.2. Front spring(s) are unrestricted except that the front suspension lifting spring(s) must be a continuous unit measuring 37.63" (+ or - .13") in length, is completely housed internal of the torsion spring tube(s), and fit unaltered control arm spring sockets.

2.1.3. Removal of the shock towers above the upper H-beam tube centerline.

2.1.4. Relocation of the shock dampers is permitted. Shock dampers and their actuation are free providing that no VW components are altered, modified or changed unless specifically authorized herein. Bump rubbers with a maximum length of 2 1/2" may be used to protect the shock(s)/chassis from bottoming. Use of related bump rubber packing washers/solid spacers is free. Coil spring mounted (coil-over) shocks are not permitted.

2.1.5. The use of any anti-sway bar or bars, internal or external, mounting hardware, and trailing arm locating spacers. The anti-sway bar fitted as part of the standard suspension may be removed. Sway bars may not be cockpit adjustable. Front suspension Z-bars are not permitted.

2.1.6. Replacement of torsion bar rubbers with spacers of another material.

2.1.7. Installation of ride height adjuster(s), constructed for use with standard VW spring packs, to the H-beam allowing rotation of the spring pack. One (1) ride height adjuster per torsion spring tube is permitted. No cockpit adjustment of ride height is permitted.

2.1.8. Removal of the brake backing plates.

2.1.9. Camber/caster eccentric adjusting nut may be replaced with an aftermarket nut of different design. Caster, camber, and toe-in are free.

2.1.10. Any wheel bearings that fit the VW type 1 spindles and disk brake hubs without modification may be used.

2.1.11. Steering column may be altered or replaced. Steering wheel is free, and may be detachable. Steering mechanism is free, but tie rods must attach to the spindle using existing steering arm, a modified steering arm, or a suitable new or modified bracket welded to the spindle. Ball joints in the tie rods may be replaced with rod ends.

## **2.2. Rear Suspension**

**2.2.1.** The rear axle and tube assembly shall be standard VW Type I up to 1966, sedan swing axle (no outer pivot point for a half shaft) with axle location provided by a single locating arm on each axle. The rear axle tube may be rotated about its axis. The standard shock mounting and brake pipe brackets may be removed. Rear axle O.A. length: 26 11/16" + or - 1/8"

**2.2.1.1.** The rear axle bearing retainer flange mating surface may be machined, or shims may be installed under the rear axle bearing, for the sole purpose of adjusting bearing axial float.

**2.2.2.** Springs, shock dampers, their actuation, and camber compensating devices are free.

## **3. Braking System**

**3.1.** Standard VW Type 1 disc brake components must be used, including any standard VW Type 1 original or aftermarket direct replacement brake caliper constructed of cast iron material. Front rotor minimum weight: 13.0 lbs. each without wheel mounting studs.

**3.1.1.** Caliper housing material may be removed on the outer radius surface of the outer piston housing to clear the inside of the rotating wheel. This metal removal shall only be to allow wheel clearance.

**3.2.** Any type pad material may be used on standard VW Type 1 brake pads.

**3.3.** Adapter plates may be fitted to allow mounting of front or rear brake calipers.

**3.4.** Cross-drilling or grooving of rotors is not permitted.

**3.5.** Rear brake drum assemblies must be removed and replaced with one-piece cast iron rear brake rotors with machined-in rear axle splines. Caliper mounting is free. Min. rotor weight: 15.0 lbs each, without wheel mounting studs.

**3.6.** The car shall be equipped with a dual braking system operated by a single control. In case of a leak or failure at any point in the system, effective braking power shall be maintained on at least two wheels.

**3.7.** A separate hand brake is not required. Removal of the hand brake and operating mechanism is permitted.

**3.8.** Brake lines may be of any suitable material, including steel braided lines.

**3.9.** Wheel mounting lug bolts may be replaced with studs.

**3.10.** All brake components must remain within the safety tolerances and minimum dimensions established by the component manufacturer.

**3.11.** Rear drum brakes on existing homologated Formula First cars will be allowed until 1/1/09

## 4. Wheels and Tires

4.1. Wheels shall be 13" diameter by 6" wide. (+ or - 1/8" for all dimensions)

4.1.1. Wheels must be of one-piece construction and may be constructed of steel, aluminum, or magnesium, but each wheel must comply with a minimum weight of 10 pounds, less tire, wheel weights and valve stem assembly.

4.1.2. Wheel bolt pattern is free, except that it must use 4 lug bolts or studs with lug nuts. No centerlocks. As a recommended standard, the common bolt pattern for Formula First is 4"x 4 bolt.

4.1.3. Spacers between the wheel and rotor are permitted.

4.2. Tires shall be Formula Ford slicks in standard front and rear sizes and using a hard compound. The Region, Division and/or racing series sanctioning the races shall specify which manufacturer or manufacturer's tires meeting this general description shall be permitted.

### Regional, Divisional and/or Race Series Tire Options:

4.2.1. **Option 1.** The spec tire manufacture for Formula First shall be Hoosier Tire. Front tires shall be #43130 20.0"x 6.0" - 13" R60 compound. Rear tires shall be #43302 22.5"x 7.5" - 13" R60 compound.

4.2.2. **Option 2.** The spec tire manufacture for Formula First shall be Goodyear Tire. Front tires shall be #807-366-068 3321 20.0"x 6.0" - 13" R600 compound. Rear tires shall be #870-274-068 2015 22.5"x 7.5" - 13" R600 compound.

4.2.3. **Option 3.** The spec tire manufacture for Formula First shall be American Racer Tire. Front tires shall be 20.0"x 6.0" - 13" 133 compound. Rear tires shall be # 22.5"x 7.5" - 13" 133 compound.

4.2.4. Inter divisional races or special events may choose to allow more than one tire option by listing the options allowed for said event in the event supplemental regulations.

4.3. Any tires (brand, size, tread or construction) fitting the 13 x 6 rims may be used when the Chief Steward declares a rain race.

## 5. Engine

5.1. The engine shall be the standard VW "1600" (1584 cc) twin port, unless otherwise stated in these rules.

5.1.1. Engine components shall be assembled in standard configuration. Exceeding the wear limits specified in the VW manual or in other official VW guides is permitted provided that the specifications, tolerances, and dimensions specified in these rules are not exceeded.

5.1.2. Standard engine reconditioning practices are permissible as set out below. Such machining shall occur on the same plane as original VW specification. It is not permissible to add metal or any other material to any engine component, unless specifically stated herein.

5.1.3. Balancing of the following moving parts of the engine is allowed: pistons, connecting rods, crankshaft, flywheel, front pulley, and clutch disc and clutch cover. Balancing may not remove more material than is necessary to achieve the balance, except on those component parts where minimum weights are specified herein. The addition of weight to the clutch cover plate, for the sole purpose of achieving balance, is permitted.

**5.1.4.** Polishing of the contact faces of moving parts is permitted.

**5.2.** 1584 cc engine dimensions

Bore 85.7 mm maximum

Stroke: 69.1 mm maximum

Exhaust valve diameter: 32.06 mm maximum

Intake valve diameter: 35.56 mm maximum

Intake port dimension at head: 33 mm maximum

Exhaust port dimension at head: 33 mm maximum

Intake manifold horizontal inside diameter: 32 mm maximum

Manifold casting maximum diameter at flange: 33 mm maximum

Maximum valve lift: .455". Measured at Valve cap with 0" lash. An average of the four exhaust valves must be .455" or less and an average of the four intake valves must be .455" or less.

Rod weight with bolt and small end bushing: Minimum 570 grams. Rod length, center to center: 5.35" to 5.45". Any piston rod may be used that meets the VW dimensional and weight specifications listed herein.

Piston weight with pin: Minimum 515 grams.

Minimum distance: Top of piston to top edge of #1 ring groove: 8.0 mm

Crankshaft weight: 20 pounds minimum

Flywheel: Clutch diameter 200 mm; weight - 12 pounds minimum

Deck height: .045" minimum

Cam followers: 90 grams minimum

Rocker arms: 80 grams minimum (w/o adjuster)

**5.3. Crankcase, Clutch and Flywheel**

**5.3.1.** Any 1200 or 1600 VW case or exact replica may be used. (Aftermarket competition cases that vary in design from the original VW case are not permitted.)

**5.3.2.** Standard reconditioning of the case halves is permitted.

**5.3.3.** The case may be drilled to accept an external oil cooler or oil filter.

**5.2.3.** Generator/alternator, stand, and fan housing and fan may be removed.

**5.3.4.** Oil baffles may be installed. They must be housed completely within the original oil sump and crankcase.

**5.3.5.** An oil temperature sending unit may be installed in the crankcase.

**5.3.6.** Oil galley plugs may be replaced with threaded plugs.

**5.3.7.** Cylinder head studs may be replaced with studs of different material.

**5.3.8.** The crankshaft may be ground and the case may be machined to accommodate the use of the standard VW oversize/undersize crankshaft bearings, provided the crankshaft location is not changed. It may also be machined to permit installation of camshaft bearings.

**5.3.9.** The use of an aftermarket counterweighted crankshaft with standard VW stroke, index and journal sizes is mandatory. Bearings may be standard VW undersized/oversized and rods ground to accommodate them.

**5.3.10.** Crankshaft front pulley is free.

**5.3.11.** The flywheel may be lightened to a minimum of 12 pounds. Flywheel dowels may be reconditioned. Additional dowels may be added on the same face. The flywheel clutch plate surfaces may be machined.

**5.3.12.** Any 200 mm VW clutch disc, pressure plate and throwout bearing (or replacement replica) as fitted to the VW Type 1, 2 and 3 are permitted. The standard VW clutch actuation arm may be modified to allow its attachment to the standard VW clutch throwout bearing shaft in any appropriate position. Clutch **shaft arm** actuation (cable, levers, or hydraulic) is free.

**5.3.13.** Oil filler/engine vent(s), **dry sump tank** and catch tank(s) are unrestricted provided they meet SCCA GCR 17.26. (pg 92)

**5.3.14.** **The installation of a crankshaft pulley oil seal is permitted.**

**5.3.15.** The installation of case center main web location pins or shuffle pins are permitted.

#### **5.4. Camshaft.**

**5.4.1.** Only the Engle W110 camshaft is permitted. Specifications listed herein are for checking purposes only. Re-grinding of the Engle W110, or any camshaft, to meet or maximize these specifications is strictly prohibited.

Cam lift: Exhaust and Intake .392" variance + .003"

Lobe centers: 108 deg +/- 30 sec.

Intake opens @ 19 deg. Intake closes @ 48 deg. (at .050" valve lift) (+/- 30 sec)

Exhaust opens @ 55 deg. Exhaust closes @ 12deg. (at .050" valve lift) (+/- 30 sec)

**5.4.2.** Cam timing (advance/retard) may be achieved by offset keys or adjustable cam gear. Cam timing may not be adjustable without disassembling the case. No form of VTEC, cockpit adjustment, or other variable cam timing is permitted.

**5.4.3.** Cam gear must be of stock dimensions, including angle and width of teeth.

**5.4.4.** Cam followers may be reconditioned **and/or may contain camshaft face lubrication holes.**

## **5.5. Pistons and Cylinders.**

Pistons and cylinders shall be standard VW replacement parts or exact replicas. Any piston rings that can fit the standard grooves are permitted. Piston pin retaining clips may be replaced with Teflon buttons.

## **5.6. Cylinder Head**

**5.6.1.** The standard 040 **or 043** twin port cylinder head **are** the only heads permitted. A MOFOCO 040 head is also allowed. Other vendors will be added as requested, IF the castings are the same as the VW manufactured head along with dimensional items. (head cc's, valve size location, etc.) The intent is to allow casting duplicates that may be of better quality (longevity), appearance, and/or price.

**5.6.2.** The intake and exhaust ports are to remain in as-cast condition, except that material may be removed for the sole purpose of matching/blending for up to **.75" from the intake flange mating point and intake/exhaust valve seat.**

**5.6.3.** The combustion chamber must hold a minimum of 47 cc, with valves in place.

**5.6.4.** Replacement of valve seats and valve guides with others of standard dimensions and material is permitted.

**5.6.5.** Valves and valve seats may not be reshaped. Valve to valve seat mating surface (figure 1) shall be cut as follows. The 45 deg valve seat width (figure 2) shall be maintained by cutting a 15 deg chamfer (figure 3) at the outside edge of the seat and a 75 deg chamfer (figure 4) at its inner edge. Seats cannot be refaced if too little material remains for a 15 deg chamfer to be cut without going beyond the boundary of the insert. If the chamfer extends to the head, the seat or the head must be replaced.

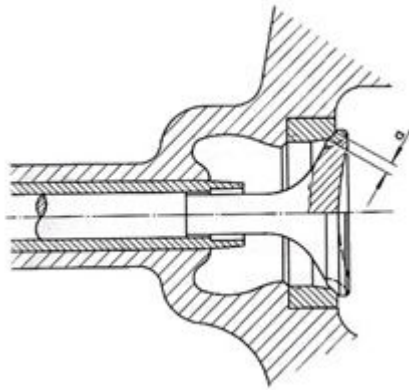

**Fig 1**

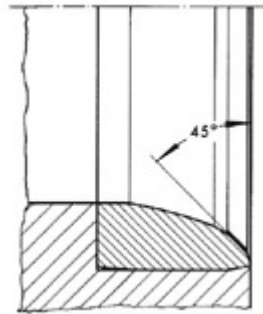

**Fig 2**

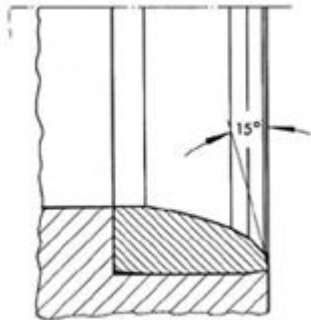

**Fig 3**

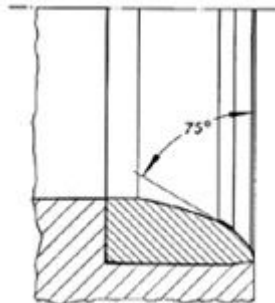

**Fig 4**

**5.6.5.1. Valve specifications (figures 1 & 5):**

Dimension "a" – valve seat contact width: Intake – 1.30 mm to 1.60 mm

Exhaust – 1.70 mm to 2.00 mm Seat contact angle on valve: 45 deg Intake and Exhaust

Dimension "A" – valve head dia: Intake – 35.56 mm max. Exhaust – 32.06 mm

Dimension "B" – valve length: 110.5 mm to 112.5 mm

Dimension "C" – valve stem dia: Intake – 7.94 mm min. Exhaust – 7.91 mm

Dimension "b" – valve head margin: Intake - .80 to 1.50 mm Exhaust – 1.00 to 1.70 mm

Dimension "d" – face angle of valve only: Intake - 44 deg Exhaust – 45 deg

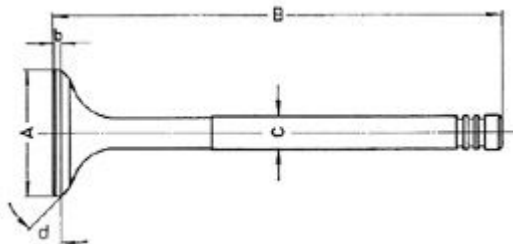

**5.6.5.2. Maximum allowable O.D. of intake seat - 40mm.**

Maximum O.D. of the 45 deg. angle on intake seat shall not exceed the outer diameter of the original VW intake seat (37mm). Maximum depth of replacement seat - 10mm.

Maximum allowable O.D. of the exhaust seat - 37mm.

Maximum O.D. of the 45 degree angle on the exhaust seat shall not exceed the outer

diameter of the original VW exhaust seat (34mm).  
Maximum depth of replacement seat - 10mm

**5.6.6.** Stainless steel valves of the same dimensions as stock are permitted.

**5.6.7.** Single valve springs must be used, but are otherwise free except that no unauthorized modifications to other parts may be made to accommodate them.

**5.6.8.** Shimming of valve springs is permitted.

**5.6.9.** Combustion chambers are to remain in standard, as cast condition, except that fly cutting is permitted to obtain the permitted compression ratio. No other tooling or polishing of the combustion chamber is permitted.

**5.6.10.** Any aluminum or steel pushrod may be used. Length is free.

**5.6.11.** Only standard 1.1:1 ratio 1600 rocker arms may be used. The two bars need to be visible. Minimum rocker arm weight listed under 5.2.

**5.6.12.** Wavy washers in the rocker gear may be replaced with solid washers.

**5.6.13.** Swivel-foot valve adjusters may be used, provided that they are on the same center plane as the standard screw and offer no increase in valve lift.

**5.6.14.** The rocker shaft posts may be shimmed to restore original geometry after authorized fly cutting.

**5.6.15.** Spark plug holes may be repaired using standard thread repair methods, such as Helicoil inserts, providing that the spark plug centerline is not changed.

**5.6.16.** Valve covers are unrestricted and may be bolted on.

**5.6.17.** Push rod tubes are unrestricted.

**5.6.18.** Any ferrous metallic valve spring retainers and keepers are permitted.

## **5.7. Oil system**

**5.7.1.** Any standard VW Type I, or replacement replica in size, shape, and material, oil pump may be used. Oil pump pressure port plugging is permitted.

**5.7.2.** Any oil pump cover may be used.

**5.7.3.** A dry sump oiling system **is permitted**.

**5.7.3.1.** The dry sump pump must bolt into the standard location, must be driven by the camshaft and have no more than two stages.

**5.7.4.** A sump extension may be fitted using or in place of the oil strainer cover plate. The oil pump pickup pipe may be extended into the sump extension. The sump extension shall not extend below the lower frame members surrounding the engine.

**5.7.5.** Any oil cooler is allowed provided it is located within the bodywork and behind the firewall.

**5.7.6.** An alternate oil pressure regulator spring or springs may be used.

**5.7.7.** A standard or racing type automotive oil filter of not more than one-quart capacity may be installed provided it is located within the bodywork and behind the firewall. No cooling fins are permitted on the filter or connecting lines. Connecting lines shall not exceed 12 feet in total length, including oil cooler connections if part of the oil filter circuit.

## **5.8. Fuel pump**

**5.8.1.** Fuel pump is free. A block off plate may be installed if the mechanical fuel pump is removed.

## **5.9. Carburetor.**

**5.9.1.** Only the Mexican made Bocar 34 PICT/3 replacement carburetor shall be permitted. The carburetor shall be in "as new" condition. The carburetor may be cleaned with commercially available "carb cleaner". NO MEDIA BLAST CLEANING IS PERMITTED. Original replacement replica gaskets, float, needle & seat may be replaced as needed. Float level may be adjusted via shim(s) under the needle & seat. Only the modifications listed herein are permitted. If you don't see it listed herein, you can't do it, NO EXCEPTIONS.

**5.9.2.** The choke plate, choke heater element and related components, choke shaft and related hardware may be removed and the shaft holes taped or plugged. Any air filter, air horn, or combination of filter and horn may be used.

**5.9.3.** Modification or removal of the idle shutoff solenoid to allow air/fuel flow without power is permitted.

**5.9.4.** Main fuel and air correction jet sizes are free.

**5.9.5.** The carburetor may be rotated 180 degrees about its vertical axis.

**5.9.6.** The choke heater element housing may be cut off the carburetor top housing.

**5.9.7.** The fuel inlet must be threaded into the carburetor top housing, the original brass swaged in fitting is not permitted.

**5.9.8.** Vacuum fittings may be removed and ports plugged.

**5.9.9.** The full throttle stop bracket may be modified to allow for full throttle operation.

**5.9.10.** Throttle plate screws shall be "as supplied" from Bocar, no grinding, filing or trimming on these screws, NO EXCEPTIONS.

**5.9.11.** NO OTHER TOOLING OR MODIFICATIONS ARE PERMITTED. REBUILDING IS NOT AN EXCUSE FOR MACHINING, MODIFYING OR CHANGING ANY DIMENSIONS OR ANY COMPONENT OF THE CARBURETOR, NO EXCEPTIONS.

**5.9.12.** Carburetor dimensions: Specifications listed herein are for checking purposes only. Re-working of the Bocar PCIT/3 to meet or maximize these specifications is strictly prohibited.

Throttle plate thickness: .055" Minimum  
Throttle shaft thickness: .210" Minimum  
Venturi/Choke inside dimension: 26 mm Maximum

## 5.10. Intake Manifold

**5.10.1.** The intake manifold shall consist of standard VW Type 1 1600 (1584 cc) twin port components, or direct replacement, unless stated otherwise in the following rules.

**5.10.2.** The heat sink casting may be removed or modified.

**5.10.3.** Other EXTERNAL modifications to the cast sections are permitted for clearance purposes, provided no performance advance results.

**5.10.4.** The standard 1600 manifold end castings must be untouched internally other than for the purpose of port matching.

**5.10.5.** Port matching to a depth of 1.0" into the manifold casting from the manifold/head joining surface is permitted.

**5.10.6.** The official Formula First 32 mm restrictor plate must be installed per the following instructions listed. **Absolutely no modifications are permitted to the restrictor plate. Any defects or marks on the blue anodize is not allowed and must be exchanged immediately for a new official Formula First 32 mm restrictor plate.**

**5.10.6.1** The official Formula First 32 mm restrictor plate must be installed/assembled exactly in the following order, using only the listed parts. **No exceptions allowed.**

1. Intake manifold
2. (1) Standard VW (or direct replacement) carburetor gasket
3. Official Formula First 32 mm restrictor plate
4. (1) Standard VW (or direct replacement) carburetor gasket
5. Bocar 34 PICT/3

**5.10.6.2.** Installation diagram supporting 5.10.6.1.

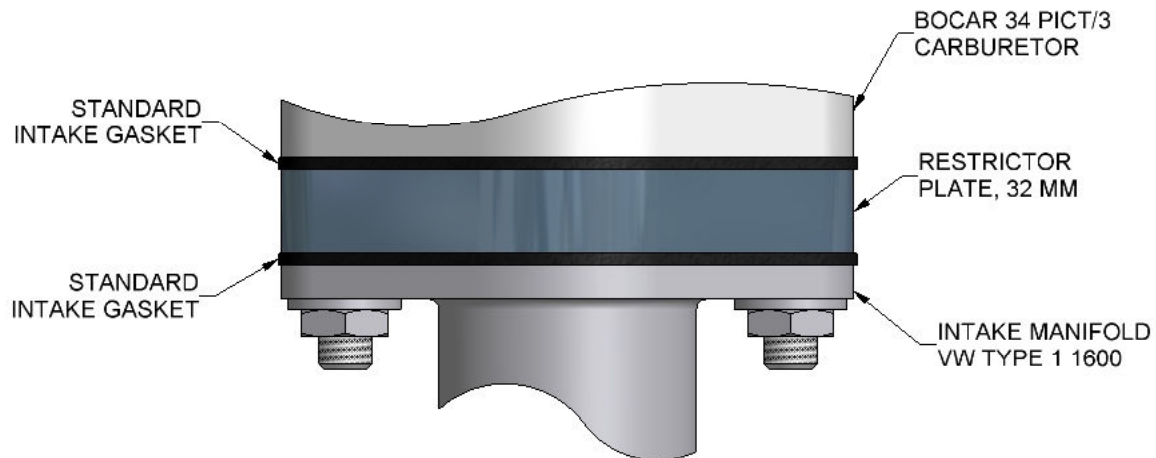

**5.10.6.3.** Any Formula First car may be subject to a "spot check" for restrictor plate compliance. A spot check may be visual or may require a vacuum leak check performed as follows:

1. Run engine at 2500 RPM
2. Seal the carburetor air inlet
3. Engine must stall within 4 seconds

**5.10.7.** All intake manifold vacuum fittings or ports must be plugged.

#### **5.11. Engine cooling system.**

**5.11.1.** The air-cooling system for cylinders and cylinder heads is free, subject to limitations on bodywork. See 5.7.7. with respect to oil coolers and lines.

#### **5.12. Exhaust System**

**5.12.1.** The exhaust system is free, but must comply with SCCA and local noise requirements and with overall body dimensions requirements.

#### **5.13. Electrical System**

**5.13.1.** 12-volt electrical systems shall be used.

**5.13.2.** The distributor must be a standard VW mechanical advance distributor, or Bosch 009, or a replacement replica, with the following modifications permitted.

**5.13.3.** The advance curve may be adjusted.

**5.13.4.** Standard Bosch or replica points may be replaced with an electronic replacement points set (Pertronix, Comp-U-Fire, etc.). The replacement set must be totally within the distributor.

**5.13.5.** Any coil is permitted.

**5.13.6.** Any 12v on-board automotive starter capable of starting the engine from the driver's compartment is permitted.

#### **5.14. Other non-standard components.**

**5.14.1.** Use of the following non-standard replacement parts is permitted provided that no unauthorized modification of any component results: Any fasteners (nuts, bolts, screws, etc); wiring; gaskets and seals; fuel line; spark plugs (maximum 1/2 inch reach); piston rings; fan belt; and connecting rod bearings, camshaft bearings, and crankshaft main bearings, provided the bearings are of the same type and size and VW standard or oversize bearings.

## **6. Transaxle**

**6.1.** The standard VW Type 1, 2 or 3 swing axle type transaxle must be used in standard configuration unless stated otherwise in these rules. All five gears (including reverse) must be operable, and controllable from the driver's seat. Synchromesh must be operating on all four forward gears. A direct replacement transmission case, VW part # 081-301-051, or replacement replica, "Rhino" case is permitted.

**6.2.** Shock damper mounts may be modified or removed.

**6.3.** Transmission shall not be installed in an inverted position.

**6.4.** The crown wheel must be transposed in the transmission case.

**6.5.** The differential cannot be modified in any way to limit its normal function. Torque biasing, limited slip, and locked differentials are prohibited.

**6.6.** The following gear ratios must be used with the 1600(1584) engine:

1 - 3.80; 2 – 2.06; 3 – 1.26; 4 – 0.89; differential 4.125

## **7. Frame and Body**

### **7.1. Frame**

**7.1.1.** The frame shall be constructed of steel tubing with a maximum cross section of 4". The driver's feet shall not extend forward the rear edge of the front axle beam tubes.

**7.1.2.** No frame/chassis rigidity or strength shall be derived from anything other than the steel frame tubes. No stressed skin, monocoque, or semi-monocoque construction is permitted.

**7.1.3.** The firewall panel must extend the full width of the cockpit and be at least equal to the top of the carburetor in vertical height from the floor pan may be rigidly attached to the frame tubes.

**7.1.4.** The undertray(s) or belly pan(s) shall be rigidly attached to the frame provided that the curvature of said undertray(s), measured vertically from the lowest point to its highest point at its attachment point to the frame rail member at its sides, shall not exceed 1" and have no downward turned edges. Undertray(s) or belly pan(s) shall not extend more than ¼" beyond the vertical line of the closest mating bodywork.

**7.1.5.** The area between the upper and lower main frame tubes, or at least 14" above the undertray(s) or belly pan(s) whichever is greater, from the front roll hoop bulkhead to the main roll hoop bulkhead shall be protected by one of the following methods to prevent the intrusion of objects into the side of the cockpit area. For either method, fasteners shall be no closer than an average of 6" centers (no stress bearing panels). The material used for chassis braces in this area shall be at least equivalent to roll hoop brace material.

**7.1.5.1.** Panel(s): Minimum of either .060" aluminum (6061 T-6 or equivalent) or 18 gauge steel attached outside of the main frame tubes.

**7.1.5.2.** Reinforced Body: Minimum 2-layers of 5 oz. bi-directional Kevlar material laminated to the inside of the bodywork and securely fastened to the frame.

**7.1.6.** A crushable structure or crush box must be rigidly attached to the H-beam and/or frame with a minimum cross section of 200 cm sq (31" sq), at least 40 cm (15.75") forward of the clutch and brake pedals (not depressed), constructed of a minimum of 18 gauge (.052" or 1.3 mm) 6061-T4 or equivalent aluminum must be used on all Formula First cars.

### **7.2. Body**

**7.2.1.** The body shall be constructed of fiberglass, aluminum, steel, Kevlar, carbon fiber or any combination thereof.

**7.2.2.** The body must not be rigidly attached so as to form part of the structural integrity of the car.

**7.2.3. Rear (Tail) Bodywork:** The rear bodywork shall extend from the firewall to a point at least 16" aft of the rear axle centerline.

**7.2.4. Front (Nose) Bodywork:** Any bodywork forward of the front beam torsion spring tubes shall have a maximum width of 31.75" (80.65 cm)

**7.2.5. Main (Center) Bodywork:** No part of the frame or bodywork shall project beyond a plane connecting the vertical centerline of the front and rear tires. Fuel filler necks, caps or lids shall not protrude beyond the bodywork of the car. The bottom of any bodywork that extends below the frame members shall be on the same flat plane as the undertray and shall not deviate from that flat plane by more than 1".

**7.2.6. Cockpit Opening:** The driver's seat shall be capable of being entered without the removal or manipulation of any part or panel (except for a removable steering wheel and removable cockpit padding). The cockpit opening of the bodywork shall have the following minimal dimensions: Length: 60cm (23.622 inches) Width: 45cm (17.717 inches). This width extends over a length of 30cm (11.811 inches) minimum. This minimal rectangular opening may exist anywhere forward of the bracing, and required padding will not be considered in these dimensions.

**7.2.7. Air Ducting:** Air ducts may be installed for the purpose of delivering air to, or extracting air from the cylinders, cylinder heads, oil cooler and/or carburetor. Air duct opening(s) may be located within the cockpit area and/or penetrate the firewall provided the duct(s) design and construction would prohibit flame and debris from reaching the driver.

**7.2.8. Aerodynamic Devices:** Wings are prohibited. Any device specifically designed to use air speed to create aerodynamic downforce is prohibited.